

Micro Balance

MicroBalance Operating Manual

Contents

1	Introduction	3
1.1	Warning & Safety Precautions	4
1.2	Getting Started	5
1.3	Layout	6
2	Setting up the Balance	7
2.1	Location	7
2.2	Warm up	8
2.3	Keys of Balance	9
3	Power On	11
4	Simple Weighing	13
4.1	External Calibration	17
4.2	Internal Calibration	19
4.3	Calibration Test	21
4.4	Calibration Test with Actual Calibration	23
5	Overview of Menu	25
7	Parameter Settings	33
7.1	Time & Date Settings	36
7.2	ID / LID Settings	38
7.3	Auto Calibration	39
7.4	Windows Direct Communication	42

8	ISO / GLP - Compliant Printout	45
9	Data Interface	46
9.1	Data Output Format	47
9.2	Data Input Format	49
9.3	Cabling Diagram	50
10	Error Codes	51
11	Care & Maintenance	53
13	Specification	57
14	Accessories	58

1. Introduction

The models of the CX, CY, CT, CG and SSH Series are weighing instruments of special and high accuracy designed for the measurement of mass, covering a range from 0.01mg to 100 kg.

CX, CY, CT, CG and SSH models meet the highest requirements on the accuracy and reliability of weighing results through the following features:

- Filtering for unfavorable ambient conditions, such as vibration, drafts, etc.
- Stable and repeatable weighing results
- Excellent readability under any lighting conditions
- Rugged, durable weighing system

These weighing instruments speed up your simple routine applications through following features:

- Extremely fast response times
- Built-in applications
 - Counting
 - Percent weighing
 - Animal weighing
 - Formulation
 - Totalization
 - Custom Unit
 - Check Weighing
 - Density Determination
 - Pipette Calibration
 - Statistics

- Total ease of operation
- Direct Communication with MS Excel, MS Word and other windows application.
- ISO/GLP-compliant recording capability for printouts
- Serial RS-232 port for optional connection to a PC or Printer.
- Optional USB interface available on request.

1.1 Warnings and Safety precautions

The balance has been constructed in accordance with the European Directives as well as international regulations and standards for operation of electrical equipment, electromagnetic compatibility, and stipulated safety requirements. Improper use or handling, however, can result in damage and/or injury.

To prevent damage to the equipment, please read these operating instructions carefully before using your balance.

Keep these instructions in a safe place. Follow the instructions below to ensure safe and trouble-free operation of your balance.

 Do not use this balance/scale in a hazardous area/location.

 If you use electrical equipment in installations and under ambient conditions requiring higher safety standards, you must comply with the provisions as specified in the applicable regulations for installation in your country.

 Make sure that the voltage rating printed on the AC adapter is identical to your local line voltage.

 Warning when using pre-wired RS-232 connecting cables: The pin assignments in RS-232 cables purchased from other manufacturers may be incompatible with Citizen balances. Be sure to check the pin assignment against the chart on page 111 before connecting the cable.

- The only way to switch the power off completely is to disconnect the AC adapter.

- Connect only Aczet accessories and options, as these are optimally designed for use with your Aczet balances.

- Note on Installation: The operator shall be responsible for any modifications to Aczet equipment and for any connections of cables or equipment not supplied

by Aczet and must check and, if necessary, correct these modifications and connections. On request, Aczet will provide information on the minimum operating specifications

- Protect the DC adapter and the weighing instrument from contact with liquids.
- When cleaning your balance, make sure that no liquid enters the balance housing; use only a slightly moistened cloth to clean the balance.
- Do not open the balance/scale housing. If the seal is broken, this will result in forfeiture of all claims under the manufacturer's warranty.
- If you have any problems with your balance contact your local Aczet office, dealer or service center

1.2 Getting Started

Storage and Shipping Conditions

Do not expose the balance/scale to extreme temperatures, blows, shocks, vibration or moisture.

Unpacking the Equipment

After unpacking the balance/scale, check it immediately for any visible damage as a result of rough handling during shipment

If you see any sign of damage:
Contact your local Aczet office,
dealer or service center

It is a good idea to save the box and all parts of the packaging until you have successfully installed your balance.
Only the original packaging provides the best protection for shipment.
Before packing your balance, unplug all connected cables to prevent damage.

Accessories Supplied

The equipment supplied includes the following :

- Balance with display and control unit
- Operating Manual
- DC adapter
- Weighing pan
- Base Plat S.S. (CM)

Cautionary notes

Aczet balances may not be operated in hazardous areas.

Before attachment of the DC adapter, check whether the imprinted voltage value matches the local supply voltage. If it does not, contact your local ACZET dealers.

ACZET balance may only be used indoor in dry environment.

1.3 Layout

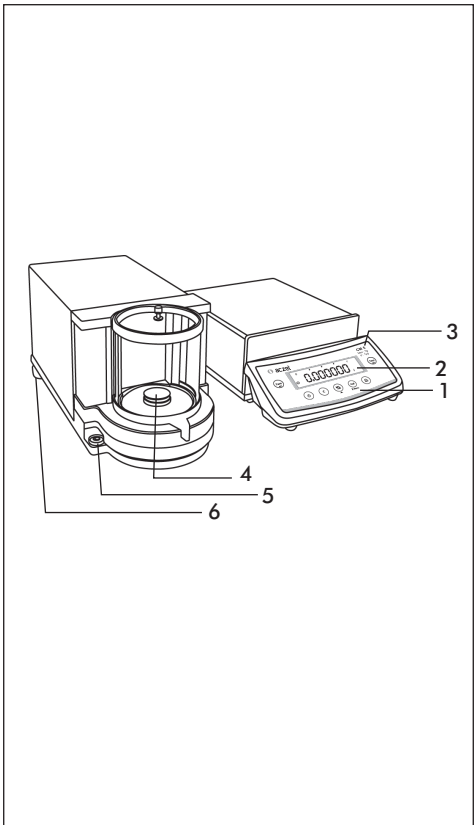

CM

1. Keypad
2. Display
3. Model plate
4. Weighing pan
5. Leveling feet
6. Spirit Level
7. RS232C interface

Keys, operation and display are identical for all ACZET balances.

2. Setting up the Balance

2.1 Location

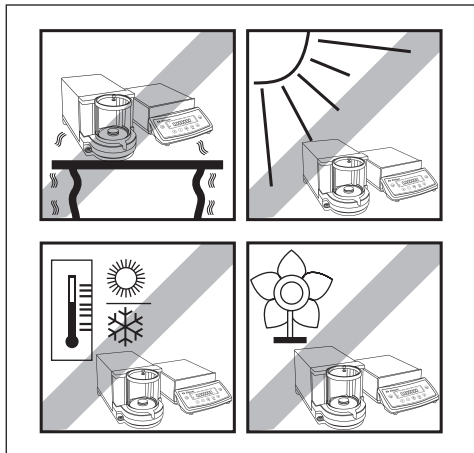

The optimum location

The correct location makes an important contribution to the accuracy of the weighing results of high-resolution analytical and precision balances.

Hence, ensure a stable, vibration-free position as horizontal as possible.

Avoid

- Direct sunlight
- Excessive temperature fluctuations,
- Drafts (Power ----- Air Conditioning System, Fans can also cause drafts)

The best position is on a stable bench in a corner protected against drafts as far possible from doors, windows, radiators or the ventilation slots of air conditioners.

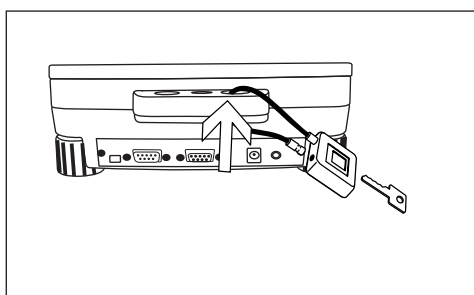

Anti-theft device

Aczet Balance are equipped with a lug for optional anti-theft device.

The anti-theft device (cable with lock) is suitable for all models. It is available from ACZET under order number CAD01.

2.2 Warm Up

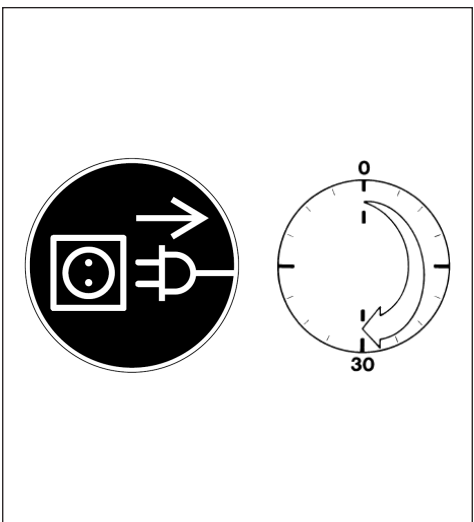

Connecting Electronic Peripheral Devices

Make absolutely sure to unplug the balance from DC power before you connect or disconnect a peripheral device (printer or PC) to or from the interface port.

Warmup Time

To deliver exact results, balance must warm up to operating temperature for at least below before the first weighing operation is carried out.

- CX / CY (0.1mg) / CT all Analytical models: at least 60 minutes
- CY (1mg) / CG / SSH all Precision models: at least 30 minutes

Using Verified Balances as Legal Measuring Instruments in the EU* balance must warm up for at least 24 hours after initial connection to DC power.

2.3 Keys of Balance

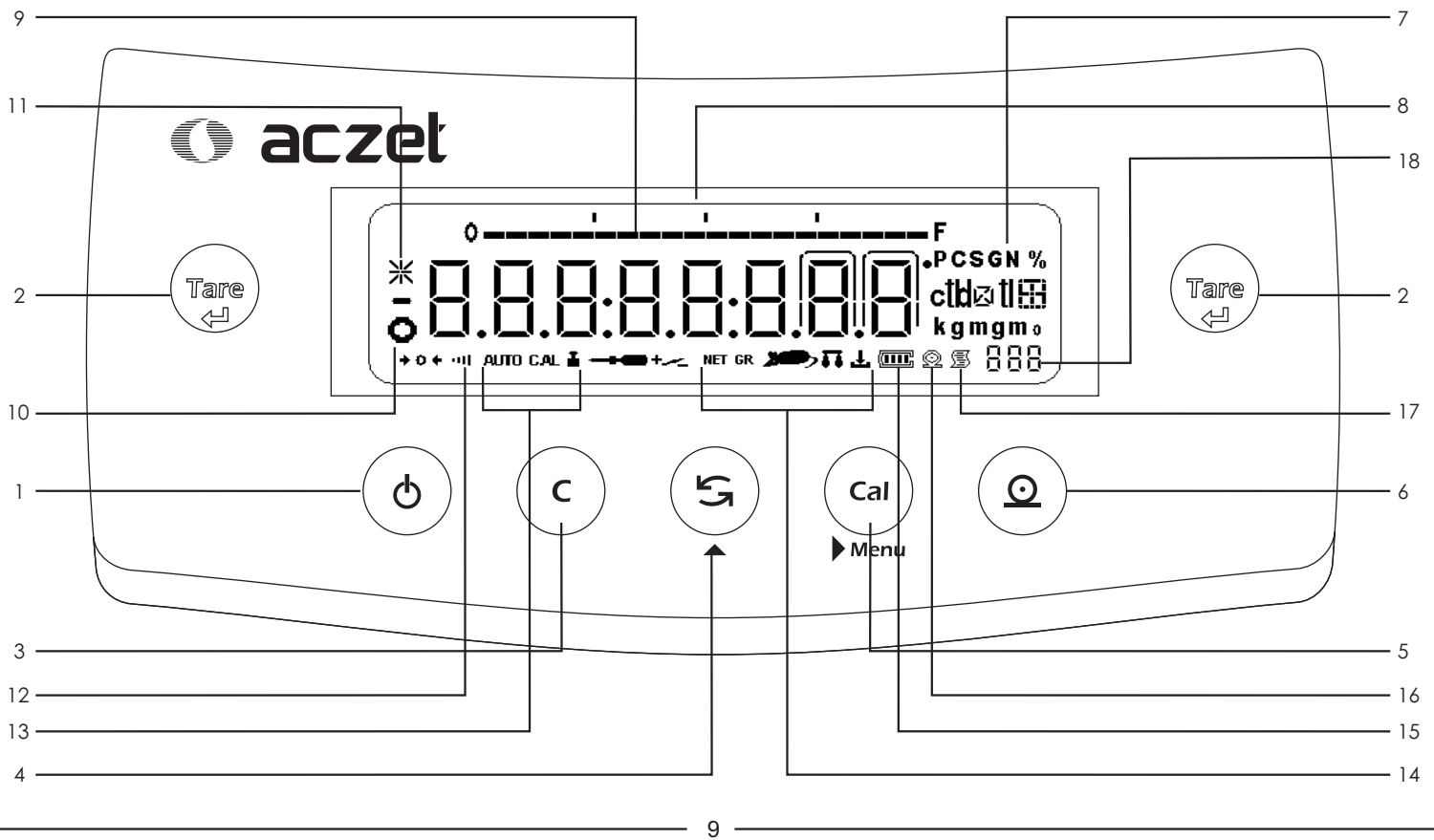

- | | | | |
|---|---|----|--|
| 1 | On/Off key: Switches the display on / off | 9 | Capacity Bar : This indicates the total amount of weight on the Pan |
| 2 | Tare key: Press here to tare the weight of any container so that the readout shows the net weight of samples, also used to store reference settings. This key used to delete the statistics when F StAt mode. | 10 | Stability Symbol : This symbol is displayed when the weight place on the pan achieve stability |
| 3 | Cancel Function : Delete (Clear Function) This key is generally used to interrupt/cancel functions; for example: – to end an application program | 11 | Asterik Symbol : This Symbol is displayed when the display is locked |
| 4 | Toggle Key : Press here to change the Unit, Also used to increment digit. | 12 | Stability Filer : This symbol indicates the chosen stability filter |
| 5 | Cal Menu Function : Press here to start calibration/ adjustment or to enter user menu, Also use to shift flashing digit from left to right. this key is used in the F PiP mode to accept the volume during the calibration procedure. | 13 | Symbol indicating that the Auto / Manual calibration/adjustment function is active |
| 6 | Print Key : Press this key to send displayed values over the built-in data interface to a DataPrint printer or a PC. | 14 | Symbol indicating the active program |
| 7 | Weight Units | 15 | Battery Level Indicator : This symbol is indicates the Current charge of the battery |
| 8 | Weight readout in the selected weight unit | 16 | Symbol indicating that a printout is being generated |
| | | 17 | Symbol indicating that a GLP compliant printout is being generated |
| | | 18 | Seven segment readout indicating the active program |

3. Power ON

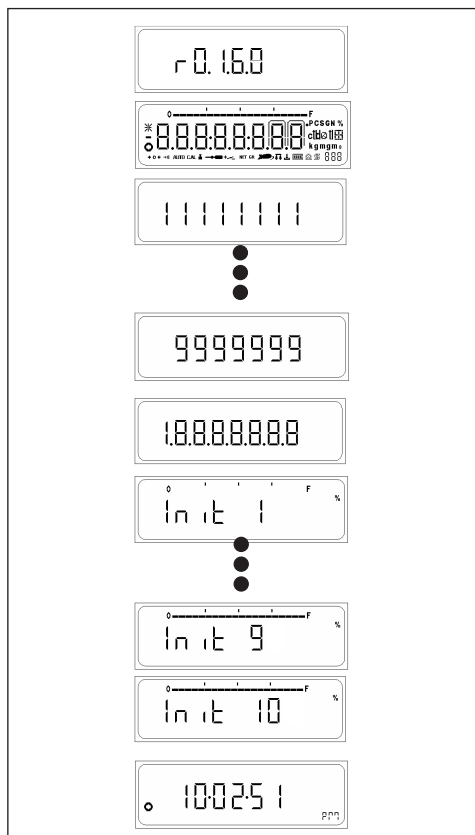

Connect DC Adaptor and Power ON the balance.

- It will display version number for software
- It will display numeric countdown
- It will display 88888888
- The system initialization process will begin with the display indicating the current progress. (INIT 1% to INIT 100%)
- After the initialization is complete (100%) It will enter stand by mode & display clock.

Stand by Mode

- After Power ON and initial test balance will automatically come in stand by mode.
- Press ON / OFF key to come to basic weighing
- Press ON / OFF key in basic weighing to come back to Stand by Mode

Key Functionality in simple weighing mode

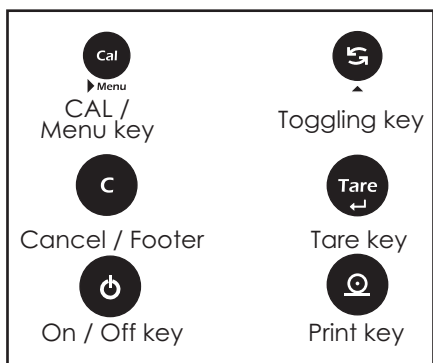
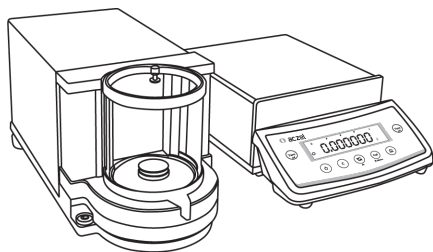

Short-form operating Instructions

- Press key **briefly**
- Press and **hold** key until desired display appears
- Automatic procedure

Aczet balances have several control levels the following section explains key functionality in simple weighing mode.

Weighing mode (operation)	
Press briefly	Press & Hold
Switch on & off	
Switch References	
Change Weighing Unit	
	Calibrate (adjust)
	Call Menu
Print Weighing Results	
Confirm Setting	Confirm Reference Setting
Abort / Cancel and Footer when GLP is ON	

4. Simple Weighing

Purpose

The basic weighing function is always accessible and can be used alone or in combination with an application program (counting, weighing in percent, etc.).

Features

- Taring the balance you can tare the balance within the entire weighing range.
- Assigning IDs to weights (as needed)
- Printing weights

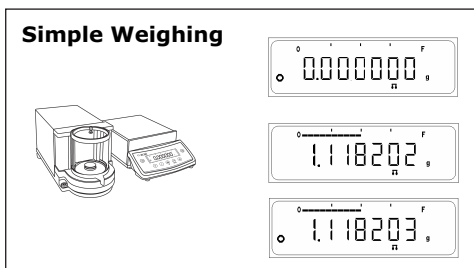

4.0.1 Simple weighing

- ⇒ Place weighing sample on the weighing pan.
- ⇒ Wait until the stability symbol appears
- ⇒ Read the result.
- ⇒ Bar Graph will glow according to weight kept ON the PAN.

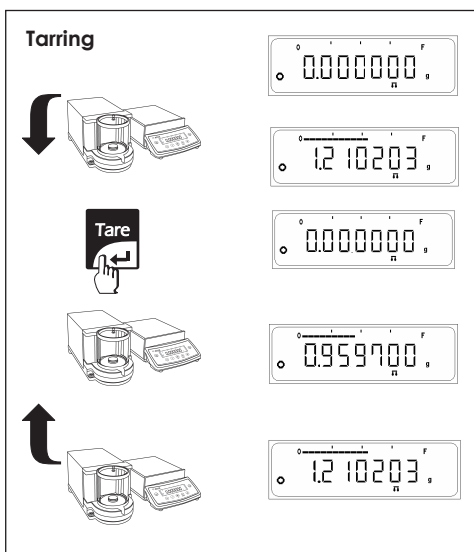

4.0.2 Tarring

- ⇒ Place empty container on the balance.
- ⇒ The weight is displayed.
- ⇒ Press <Tare> key briefly, the balance displays zero
- ⇒ Add weighing sample to container, the net weight is displayed.

If the container is removed from the balance, the tare weight will be shown as a negative value.

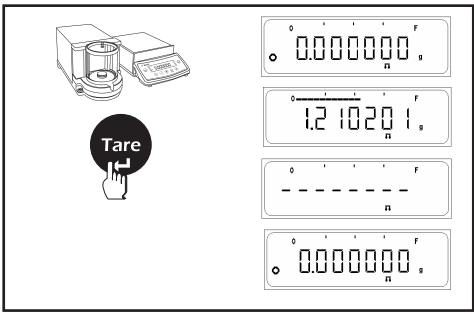

In case if stability is not achieved & user presses <TARE> key, display will shows "-----" until stability is achieved.

Display then shows "0.0000 gm"

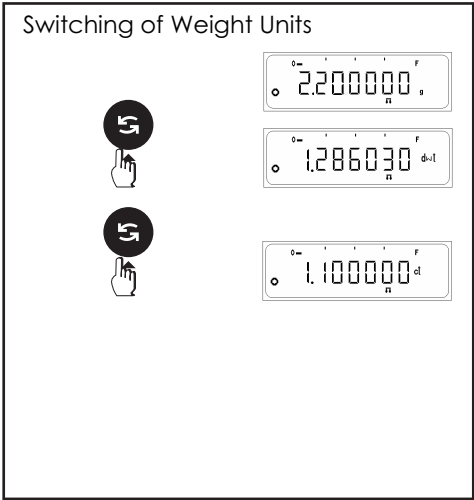

4.0.3 Switching of weight units

All Aczet balances can display weight values in different weight units.

The **factory setting** is Unit 1 (gm), Unit 2 (ct), Unit 3 (gm)

Switching between unit 1, unit 2 and unit 3

⇒ Press <TOGGLE> key the display switches to the 2nd weight unit.

⇒ Press <TOGGLE> key again, the display switches to the 3rd weight unit. OR Application unit (If same is selected in menu)

Note : With **certified balances** the unit selection can be blocked following installation if required by national legislation.

4.0.4 Simple weighing Print out

When GLP ON

Print out generated when Unit Toggling is done between Unit1 (g), Unit2 (mg), in Simple Weighing.

```

-----
20-Jul-10      10:35AM
              Aczet
Model          CM 5F
Ser.no.        9223102
Ver.no.        r0.1.6.0
ID             1234567
-----
LID:           111111
+              4.999999 g
-----
20-Jul-10      10:36AM
Name:
-----

```

When GLP OFF

Print out generated when Unit Toggling is done between Unit1 (g), Unit2 (mg), in Simple Weighing.

+ 4.999999 g

Note : 1) User cannot enter into the external calibration or menu when GLP is ON & footer has not been printed.
2) To print footer user will have to Press <CANCEL> key.

4.1 External Calibration (adjusting)

Calibration

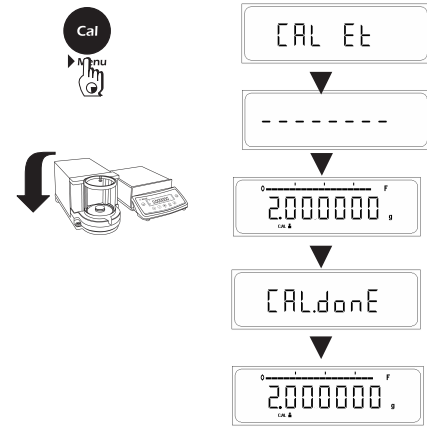

To obtain weighing results, the balance must be matched to the acceleration due to gravity at its location.

Calibration is necessary

- ⇒ Before the balance is used for the first time.
- ⇒ At regular intervals during weighing operation.
- ⇒ After a change in location.

Procedure

To obtain accurate results, the balance must be connected to the power supply and allowed to warm up to the operating temperature as described on Page No 14

Ensure that the weighing pan is unloaded and close the doors of the draft shield (if used). Balance should be Zero before calibration.

- ⇒ Have required calibration weight ready
- ⇒ Press and hold <CAL> key, display, shows "CAL Et"
- ⇒ Release <CAL> key now.
- ⇒ The required calibration weight value will be displayed.
- ⇒ Place calibration weight in center of pan.

The calibration (adjustment) is finished when "CAL donE" message is displayed. The balance is again in the weighing mode and ready for operation.

Note : With certified balances, the calibration can be disabled after installation if required by the national certification regulations.

The adjustment can be terminated at any time using the <CANCEL> key. The following message appears : 'Abort'

Calibration Report

If Balance is connected externally to PC or Data Printer via Rs232 Cable, successful or unsuccessful calibration report will be automatically generated after the completion of Calibration process.

Successful Calibration

When GLP ON

```

-----
14-Jul-10      03:46PM
      Aczet
Model          CM 5F
Ser.no.        9930508
Ver.no.        r0.1.6.0
ID             1234567
-----
Calibration:   External

W-ID          .....
Temperature    32.898'C
Set            + 5.000000g
Diff.         0.000000g
External Cal Done

Diff.         0.000000g
-----
14-Jul-09      03:46PM
Name:         .....
```

When GLP OFF

```

Calibration :   External

W-ID          .....

Temperature    32.905'C
Set            + 5.000000g
Diff.         -0.000001g
External Cal Done
Diff.         0.000000g
```

Unsuccessful Calibration

When GLP ON

```

-----
14-Jul-10      03:46PM
      Aczet
Model          CM 5F
Ser.no.        9930508
Ver.no.        r0.1.6.0
ID             1234567
-----
Calibration:   External

W-ID          .....
Temperature    32.898'C
Set            + 5.000000g

External Cal Failed

-----
14-Jul-09      03:46PM
Name:         .....
```

When GLP OFF

```

Calibration :   External

W-ID          .....

Temperature    32.905'C
Set            + 5.000000g

External Cal Failed
```

4.2 Internal Calibration

Internal Calibration

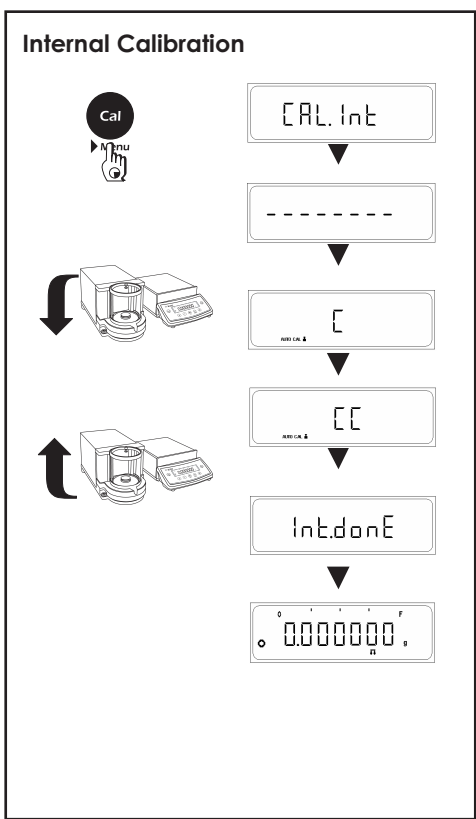

To obtain weighing results, the balance must be matched to the acceleration due to gravity at its location.

Calibration is necessary

- ⇒ Before the balance is used for the first time.
- ⇒ At regular intervals during weighing operation.
- ⇒ After a change in location.

Procedure

To obtain accurate results, the balance must be connected to the power supply and allowed to warm up to the operating temperature as described on Page No 14

Ensure that the weighing pan is unloaded and close the doors of the draft shield (if used). Balance should be Zero before calibration.

- ⇒ Press and hold <CAL> key, display, shows "CAL Int"
- ⇒ Release <CAL> key now.

Internal Calibration process Starts.....

- When the Internal Weight is being loaded "C" will be displayed on display.
- When the Internal Weight is being unloaded "CC" will be displayed on display.

Calibration is finished when 'Int.done' is message is displayed.

The adjustment can be terminated at any time using the <CANCEL> key. The following message appears : 'Abort'

Internal Calibration Report

If Balance is connected externally to PC or Printer via Rs232 Cable, successful or unsuccessful calibration report will be automatically generated after the completion of Calibration process.

Successful Calibration

When GLP ON

```
-----
20-Jul-10      10:32AM
      Aczet
Model          CM 5F
Ser.no.        9223102
Ver.no.        r0.1.6.0
ID             1234567
-----
Calibration:   Internal

Start:         Manual
Temperature    29.449'C
Diff.          + 0.000009g

Internal Cal Done
Diff.          0.000000g
-----
20-Jul-10      10:32AM
Name:          .....
```

When GLP OFF

```
Calibration:   Internal

Start:         Manual
Temperature    29.449'C
Diff.          + 0.000009g

Internal Cal Done
Diff.          0.000000g
```

Unsuccessful Calibration

When GLP ON

```
-----
20-Jul-10      10:34AM
      Aczet
Model          CM 5F
Ser.no.        9223102
Ver.no.        r0.1.6.0
ID             1234567
-----
Calibration:   Internal

Start:         Manual
Temperature    29.495'C

Internal Cal Failed
-----
20-Jul-10      10:34AM
Name:          .....
```

When GLP OFF

```
Calibration:   Internal

Start:         Manual
Temperature    29.495'C

Internal Cal Failed
```

4.3 Calibration Test

Calibration (adjusting)

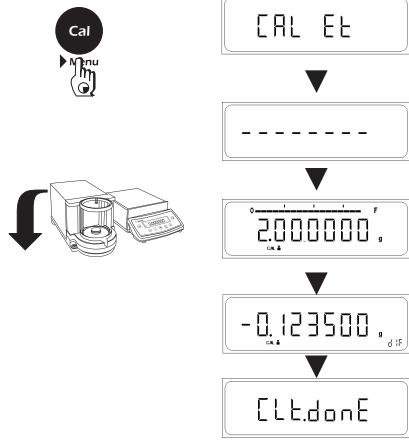

Calibration test determines the difference between the actual weight and the measured weight. Calibration test can be turned ON or OFF from the user menu. When ON, cal test would be performed on external or internal calibration whichever is selected in User Menu.

Procedure

- ⇒ Have required calibration weight ready
 - ⇒ Press and hold <CAL> key, display, shows "CAL Et"
 - ⇒ Release <CAL> key now.
 - ⇒ The required calibration weight is shown on the display.
 - ⇒ Place calibration weight in center of pan.
- ⇒ After the cal Test procedure is completed the difference between the actual & the measured weight will be displayed on display.

The adjustment can be terminated at any time using the <CANCEL> key. The following message appears : 'Abort'

Calibration Test Report

If Balance is connected externally to PC or Data Printer via Rs232 Cable, successful or unsuccessful calibration report will be automatically generated after the completion of Calibration process.

When GLP ON

```

-----
14-Jul-10      00:03AM
          Aczet
Model          CM 5F
Ser.no.        1111111
Ver.no.        r0.1.6.0
ID             860054081
-----
Calibration:   External

W-ID          .....
Temperature    30.710'C
Set            +2.000000g
Diff.         + 0.000047g
Calibration Test Done

-----
14-Jul-10      00:03AM
Name:          .....
-----

```

When GLP OFF

```

Calibration:   External

W-ID          .....
Temperature    30.710'C
Set            +2.000000g
Diff.         + 0.000047g
Calibration Test Done

```

4.4 Calibration Test with Actual Calibration

Calibration (adjusting)

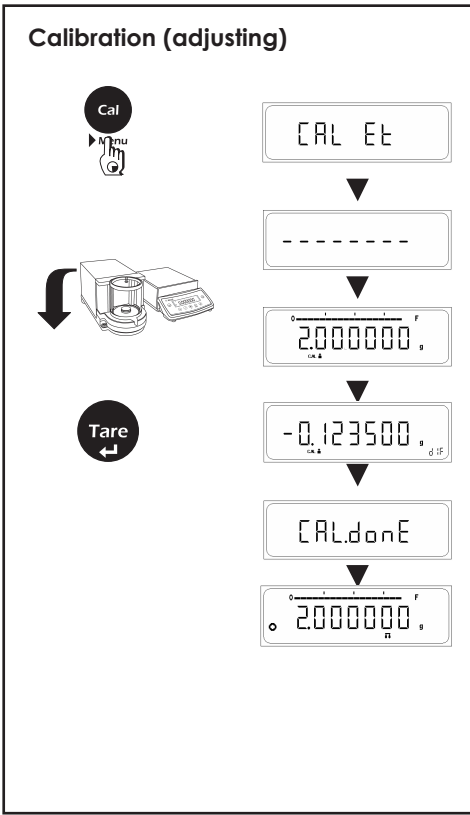

To correct the weighing results, the TARE key need to be pressed when the difference is display upon pressing the TARE key. Actual calibration is performed 'CAL done' is displayed and the weighing results are corrected as shown alongside.

Procedure

- ⇒ Have required calibration weight ready
- ⇒ Press and hold <CAL> key, display, shows "CAL Et"
- ⇒ Release <CAL> key now.
- ⇒ The required calibration weight is shown on the display.
- ⇒ Place calibration weight in center of pan.
- ⇒ The difference between the actual & the measured weight will be displayed.
- ⇒ Press the Tare key when the difference is displayed.
- ⇒ Actual Calibration is perform and Cal done is displayed.

The adjustment can be terminated at any time using the <CANCEL> key. The following message appears : 'Abort'

Calibration Test Report

If Balance is connected externally to PC or Printer via Rs232 Cable, successful or unsuccessful calibration report will be automatically generated after the completion of Calibration process.

When GLP ON

```

-----
14-Jul-10      03:46PM
      Aczet           CM 5F
Model          9930508
Ser.no.        r0.1. 6.0
Ver.no.        1234567
ID
-----
Calibration:   External
W-ID          .....
Temperature    32.898'C
Set            + 2.000000g
Diff.         -0.001235g
External Cal Done
Diff.          0.000000g
-----
14-Jul-09      03:46PM
Name:         .....
-----
    
```

When GLP OFF

```

Calibration    :      External
W-ID          .....
Temperature    32.905'C
Set            + 2.000000g
Diff.         -0.001235g
External Cal Done
Diff.          0.000000g
    
```

Key Functionality in User Menu

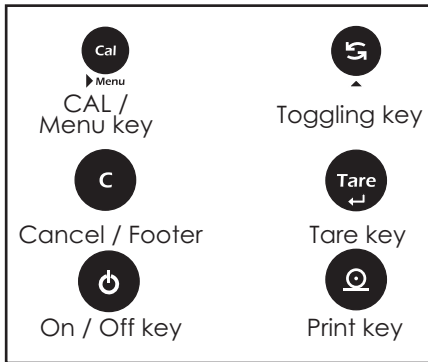
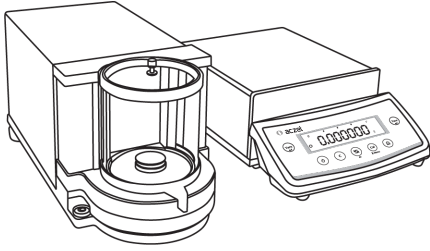

The following section explains key functionality in User Menu mode.

Menu (called up with)	
Press briefly	Press & Hold
On / Off	
Change Sub Menu Setting	
Increments the value of digit	
Change Main menu options	
Shifts the digit from left to right	
Confirm Setting	Store and quit menu
Print User Menu	
Quit User Menu	

5 Overview of Menu

In this menu, you can select unit 1, 2, 3 or Application Program, adjust the stability filter, Calibration choice, Auto Zero Tracking, automatic shutdown and print setting.

Weighing Mode

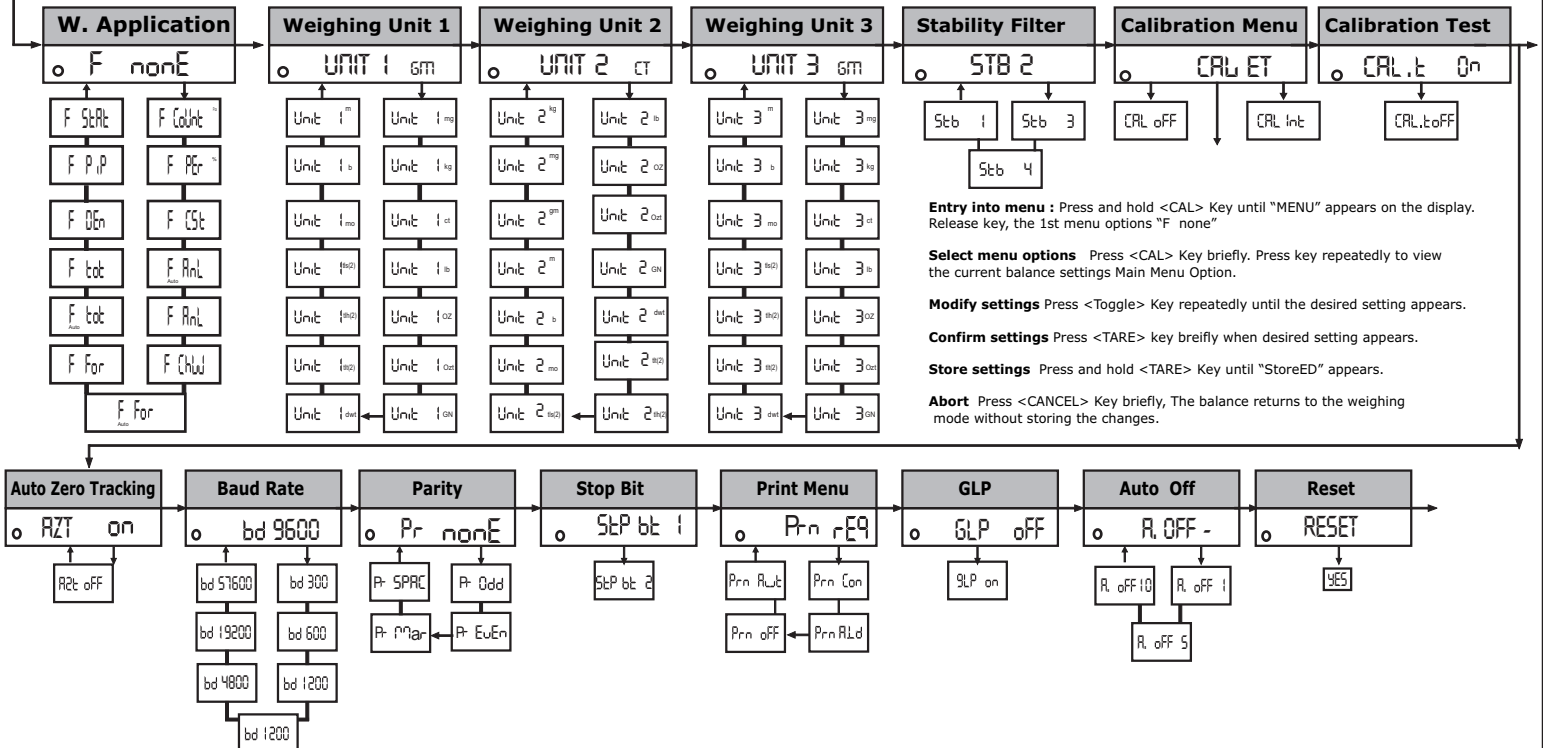

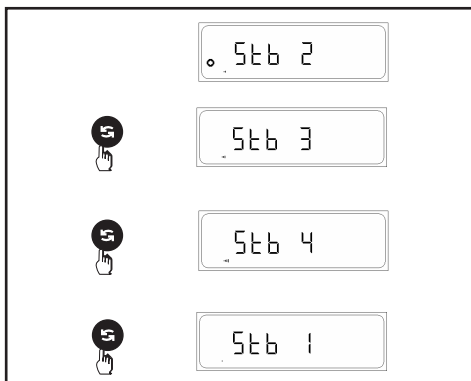

5.1 Adjusting the stability Filter

You can use the stability Filter to match the balance to the ambient conditions.

- 2 Setting with normal balance surroundings (factory setting)
- 3 Setting with unstable balance surroundings. The balance operates slower but is less sensitive to external influences (vibrations, etc.)
- 4 Setting with extreme unstable balance surroundings. The balance operates even slower but is less sensitive to external influences (vibrations, etc.)
- 1 Setting with very stable balance surroundings. The balance operates very quickly but is sensitive to external influences (vibrations, etc.)

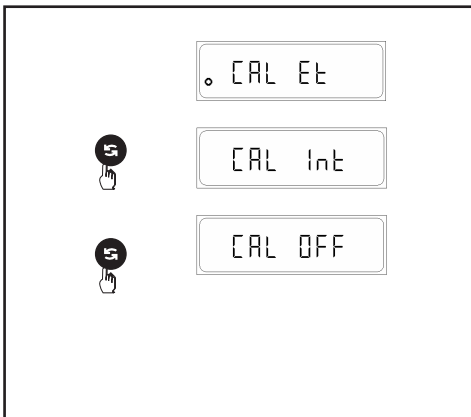

5.2 Selecting Calibration Option

User can select any of the Two option for Calibration.

CAL ET If the user select this option then the machine will perform External Calibration when the CAL key is press & hold to display "CAL Et" & at this moment if user release the key, user can enter into the External calibration.

CAL OFF When user press & hold CAL key, directly "Menu" appears on the display without CAL Et option. Thus user cannot enter into the calibration process.

CAL INT If the user select this option then the machine will perform External Calibration when the CAL key is press & hold to display "CAL Int" & at this moment if user release the key, user can enter into the Internal calibration.

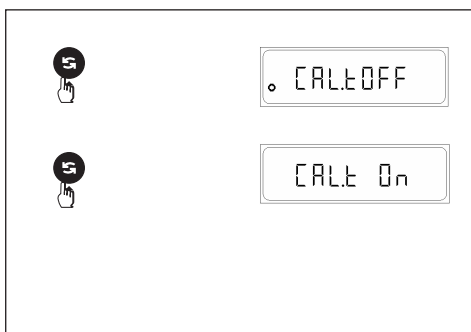

5.3 Calibration Test

User Can select any Two calibration test option.

CAL T ON If the user select this option then the machine will perform Calibration Test when the CAL key is press & hold Calibration Test will perform on Internal or External which ever is selected in calibration menu.

CAL T OFF Actual Calibration will be performed When the CAL key is press & hold .



5.4 Auto Zero Tracking

In this option, user can select whether to enable or disable Auto Zero Tracking (Factory setting is ON)

The auto zero tracking continuously corrects any deviation from the zero point for example which can be caused due to slight contamination (i.e. due to dust particles) on the weighing pan.

Print Menu

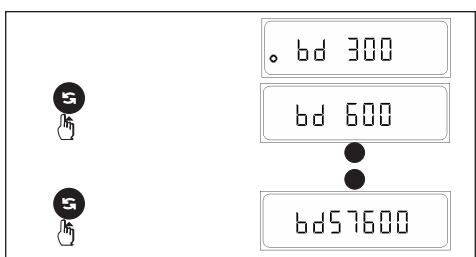

5.5 Setting baud rate (data transmission rate)

The data transmission rate (baud rate) determines the speed of the transmission via the serial interface.

The unit is baud (1 baud (bd) = 1 bit/second).

The following settings are available. bd 300, bd 600, bd 1200, bd 2400, bd 4800, bd 9600 (default), bd 19200, bd 57600

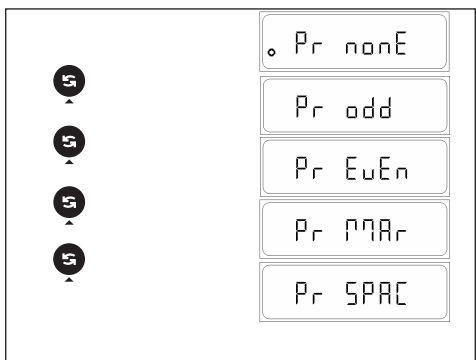

5.6 Setting Parity

This feature determines the parity of the transmitted data. The following settings are available: Parity, None (default), odd, even, mark, space.

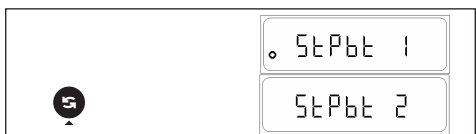

5.7 Stop Bit Selection

This setting allows the user to select the stop bit for the transmitted data.

The following settings are available: stop bit 1 (Default) and stop bit 2.

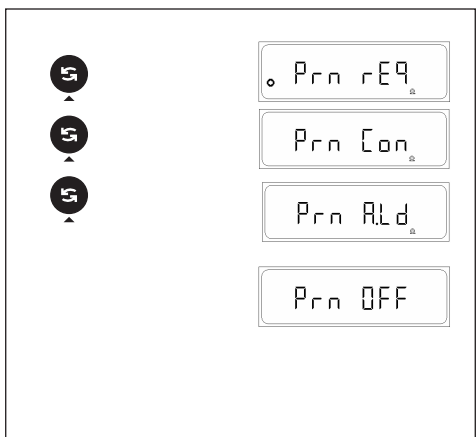

5.8 Selecting data transfer mode

In this menu block you tell the balance how a value should be transferred to a peripheral device (e.g. computer).

- Prn. req The next possible stable value will be transferred after triggering of the Print key.
- Prn. Con All Values will be continuously transferred regardless of stability.
- Prn. oFF Data Transfer mode switched off
- Prn. Aut Next Possible stable value will be transfer automatically when the display weight changes by + 1d.
- Prn A.Ld Next possible stable value will be transferred automatically when the display weight changes by +/- 10d

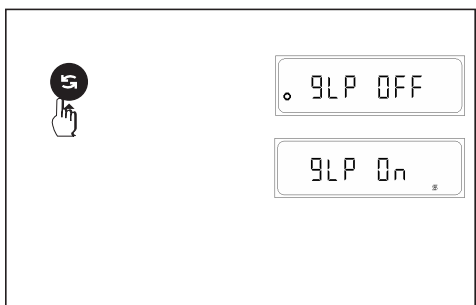

5.9 GLP Menu Setting

GLP oFF If the user select this option then the balance print format are not compliance to ISO/GLP/GMP.

GLP on If the user select this option then the balance print format are compliance to ISO/GLP/GMP.

Note

If user selected GLP ON do ensure that user print footer for entering into next transaction and enter into user Menu or Calibration.

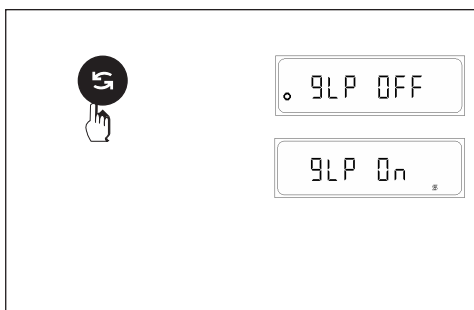

5.10 GLP Menu Setting

GLP off : If the user select this option then the balance print format are not compliance to ISO/GLP/GMP.

GLP on : If the user select this option then the balance print format are compliance to ISO/GLP/GMP.

Note

If user selected GLP ON do ensure that user print footer for entering into next transaction and enter into user Menu or Calibration.

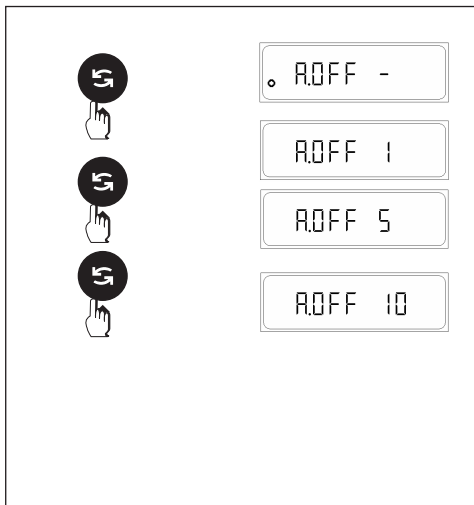

5.11 A. Off - Setting automatic standby

The automatic standby appreciably extends the operating life of your Battery (If Install) (Optional)

The balance will enter stand by mode if A-OFF is activated.

The display on the balance remains zero for a specific time as selected in the A.OFF menu.

- A. Off - : no automatic standby (factory setting)
- A. Off 1 : automatic standby after 1 minutes
- A. Off 5 : automatic standby after 5 minutes
- A. Off 10 : automatic standby after 10 minutes

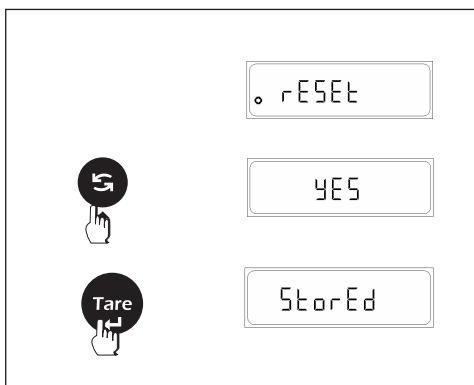

5.12 Reset of the balance setting

Reset balance setting and functions to factory setting (rESEt)

- ⇒ Select "rESEt" and Press <TOGGLE> key briefly, display show "YES"
- ⇒ Press <TARE> key briefly, display show "stored"

The balance is now reset to the factory setting and returns to the weighing mode._

Factory Setting

F none	No Function
Unit 1	gm
Unit 2	ct
Unit 3	gm
Stb 2	balance environment set to Normal
CAL Et	CAL External
CAL t	CAL TEST OFF
Azt ON	Auto Zero Tracking set ON
bd9600	Transmission rate
Pr None	Parity set to none
Stpbt 1	Stop bit one
Print	Req
GLP	OFF
A. oFF	- no automatic standby

Key Functionality in parameter settings mode

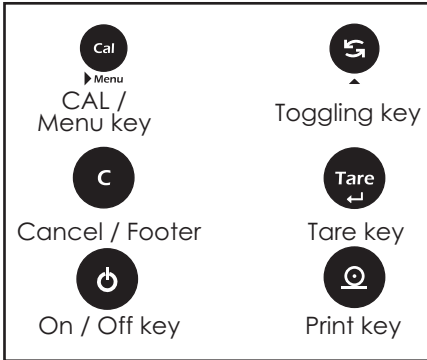
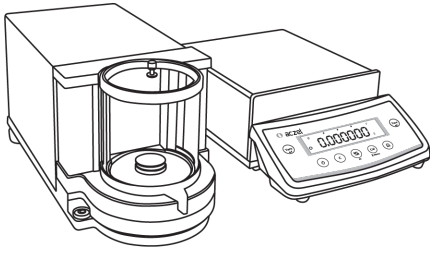

7. Parameter Settings

The following section explains key functionality in parameter settings mode.

Press briefly	Press & Hold
Change Sub Menu Setting	
Increments the value of digit	
Change Main menu options	
Shifts the digit from left to right	
Confirm Setting	Store and quit menu (Auto Cal Menu)
To Change Time Format (AM / PM / 24 hours) in Time Settings	
Quit the Current Parameter Menu	

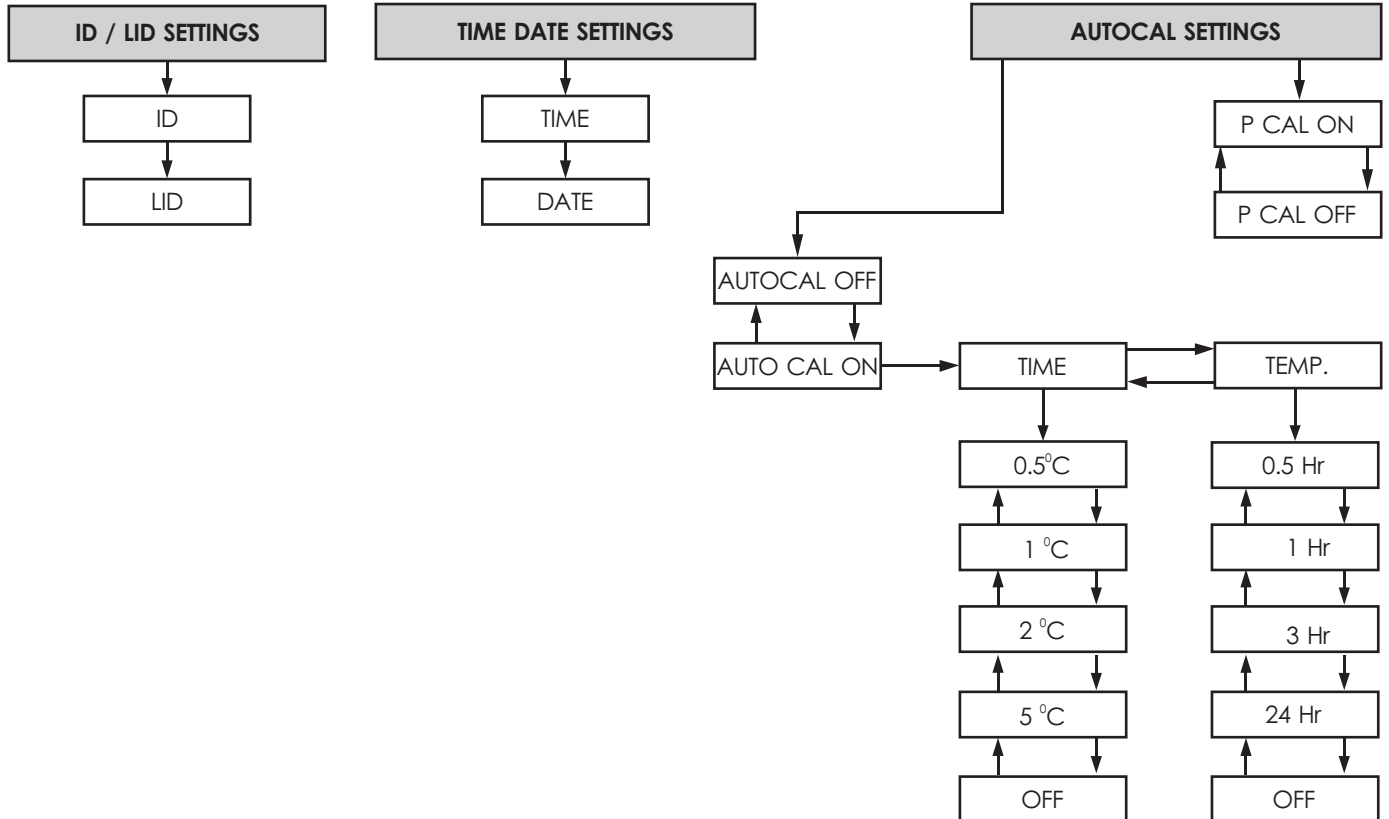

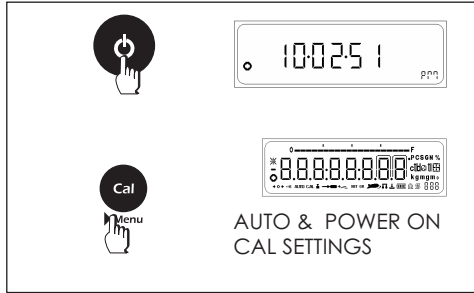
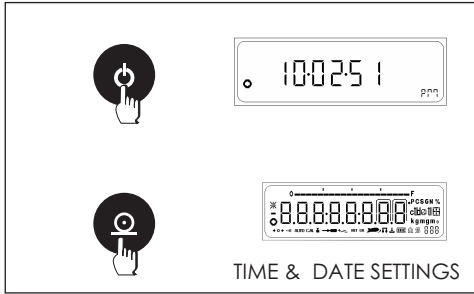
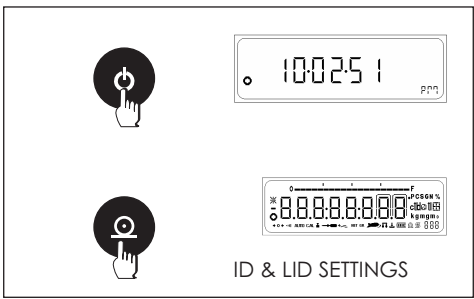

Parameter Settings

By accessing the parameter menus the user can change the following settings.

- ID and LID settings.
- Time and Date Settings.
- Auto Calibration and Power On Calibration Settings.

Operating Instructions

These menus can be accessed by pressing the PRINT key or CAL key when all the characters of the display when coming out of stand by mode or Power On.

7.1 Time & Date Setting

In this menu, User can set the Clock.

Clock setting consist of 2 settings. They are

TIME : In this submenu user can set the time in hours, minutes & seconds AM, PM & 24 hrs.

DATE : In this submenu user can set the date, Month & Years

Operating Instructions

⇒ Press the PRINT key for 2 sec when coming out from stand by or Power on mode.

7.1.1 SET TIME

- ⇒ Current Time is displayed with first digit flashing. Flashing digit indicates that digit value or place can be changed.
- ⇒ Press TOGGLE key (▲) to change the value of the Flashing digit.
- ⇒ Press CAL key (▶) to shift the flashing digit from Left to Right
- ⇒ After proper setting of time in hours, minutes & seconds respectively for zeroes starting from left, press Tare key
- ⇒ Press the PRINT key to Change the format AM, PM & 24hrs.

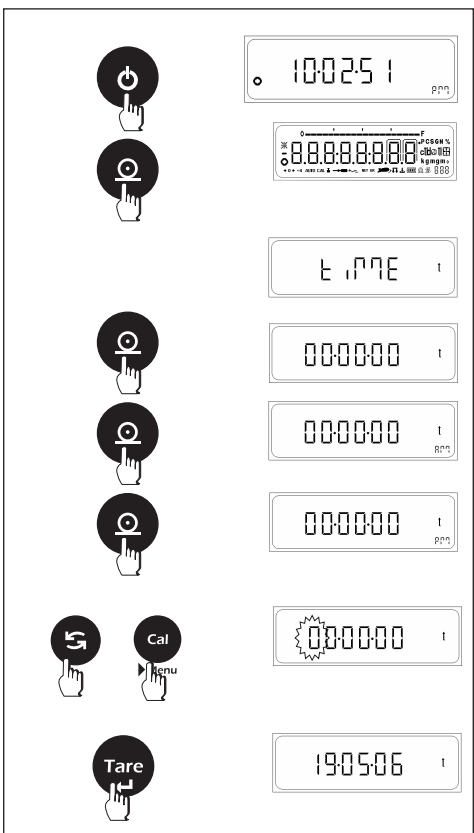

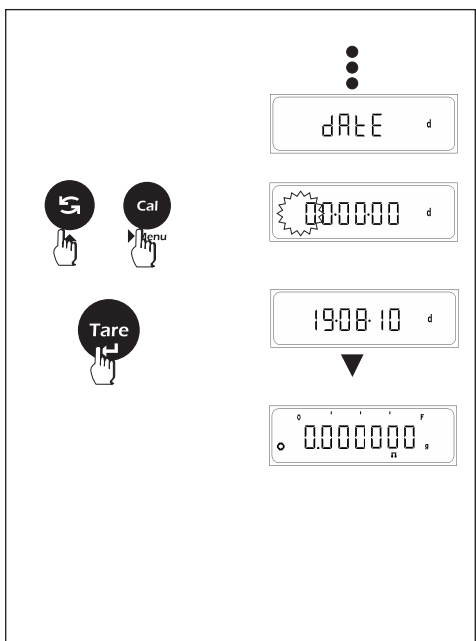

7.1.2 SET DATE

- ⇒ Press TARE key, "date" is display
- ⇒ Press TARE key, current date is displayed with first digit flashing. Flashing digit indicates that digit value or place can be changed.
- ⇒ Press TOGGLE key (▲) to change the value of the Flashing digit.
- ⇒ Press CAL key (▶) to shift the flashing digit from Left to Right
- ⇒ After proper setting of date in day, month & year respectively for zeroes starting from left,
- ⇒ Press TARE key to set the date

7.2 ID / LID Setting

In this menu user can set the identification number & Lot Identification number.

Operating Instructions

- ⇒ Press the PRINT key briefly when coming out from stand by or Power on mode.

7.2.1 SET ID

- ⇒ Last stored ID is displayed with first digit flashing. Flashing digit indicates that digit value or place can be changed.
- ⇒ Press TOGGLE key (▲) to change the value of the Flashing digit.
- ⇒ Press CAL key (▶) to shift the flashing digit from Left to Right
- ⇒ Press the TARE key to store ID Value

7.2.2 SET LID

- ⇒ Last stored LID is displayed with first digit flashing. Flashing digit indicates that digit value or place can be changed.
- ⇒ Press TOGGLE key (▲) to change the value of the Flashing digit.
- ⇒ Press CAL key (▶) to shift the flashing digit from Left to Right
- ⇒ Press the TARE key to store LID Value

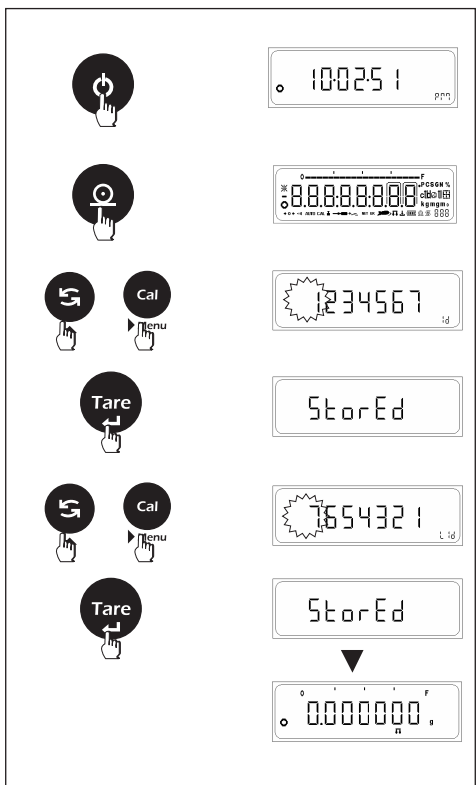

7.3 Auto Calibration

- ⇒ Auto Internal Calibration can be triggered automatically, by the following
- Time
 - Temperature
 - Power on Calibration

Operating Instruction

⇒ Press the CAL key briefly when coming out from stand by or Power on mode.

7.3.1 Auto CAL Time Settings

Select Auto CAL ON and press the <TARE> key, now press the <TARE> key when the Displays shows TIME to enter time settings.

User can set time value = 0.5 hrs.

User can set time value = 1 hrs.

User can set time value = 2 hrs.

User can set time value = 3 hrs.

User can set time value = 24 hrs.

User can set time value = OFF

Auto Cal triggered due to time will take place irrespective of cal test on or OFF

Note : The Above setting is available with balances with internal calibration.

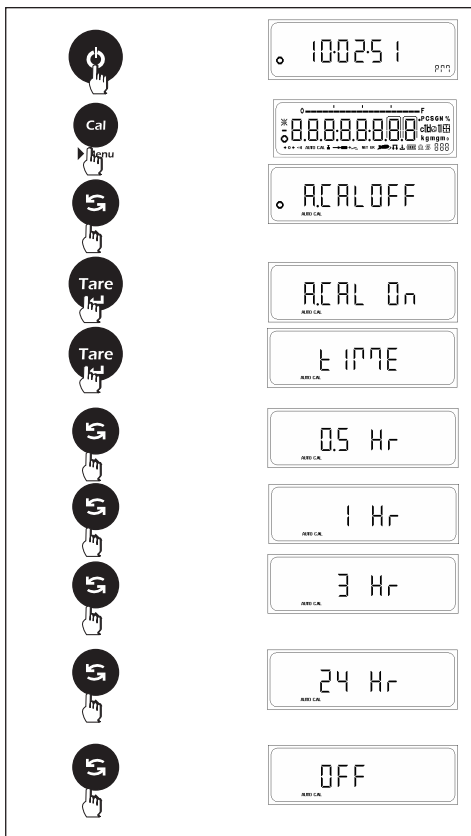

7.3.2 Auto CAL Temperature Settings

Select Auto CAL ON and press the <TARE> key, now press the <TOGGLE> key when the LCM displays TIME, press the <TARE> key to enter temperature settings.

User can set temp. value = 0.5°C.

User can set temp. value = 1°C.

User can set temp. value = 2°C.

User can set temp. value = 5°C.

User can set temp. value = OFF

Auto Cal triggered due to temp. change will take place irrespective of CAL test is On or OFF

Note : The Above setting is available with balances with internal calibration.

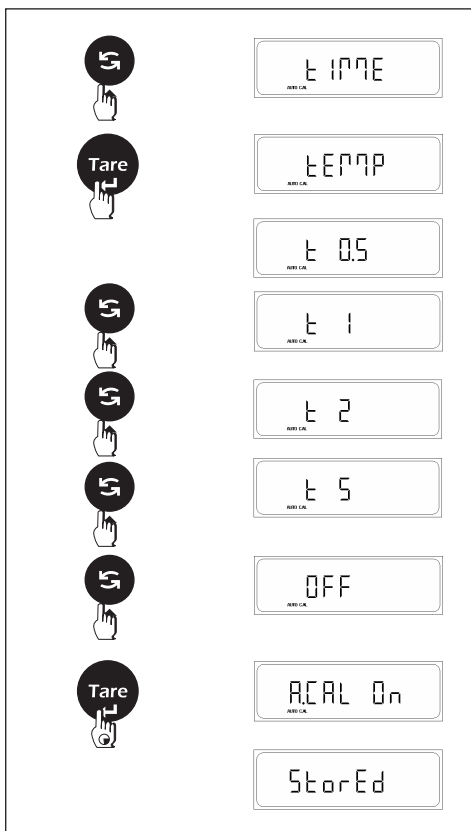

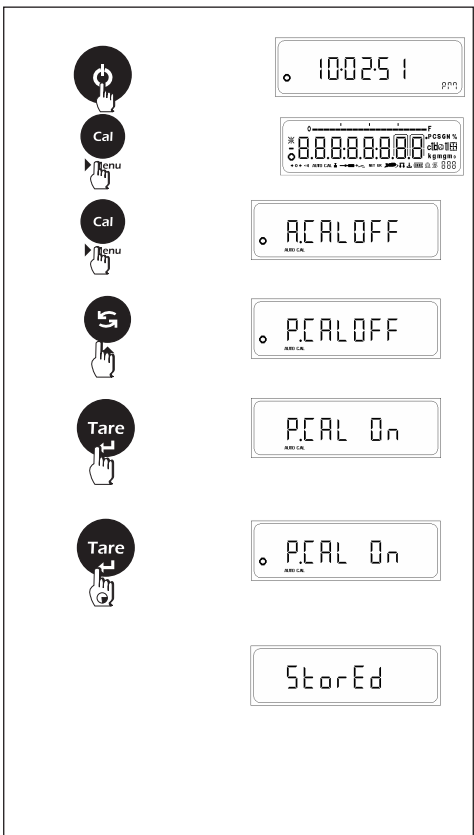

7.3.3 Power on Calibration

Press the CAL key when the LCM displays Auto CAL On or Off enter Power ON calibration options.

This setting enables the user to turn on or turn off power on calibration.

Power on calibration will take place every time the balance is powered on.

Power on Cal will take place irrespective of whether CAL Test is On or Off.

Note : The Above setting is available with balances with internal calibration.

7.4 Windows Direct Communication

The windows direct communication function enables you to send the data from the balance directly to any windows application program for e.g. Microsoft word, excel etc.

The printer settings in the user menu will be applicable to the windows direct communication also i.e. Data Transfer Mode, Baud rate, Parity, Stop Bit and GLP

The settings attributed to windows direct communication are

- Unit ON or OFF.
- Separator type ENTER or TAB.

To enable windows direct communication, make sure that you have turned it on from the windows side as well.

- ⇒ Enter control panel.
- ⇒ Open ACCESSIBILITY OPTIONS from control panel.
- ⇒ In the general tab turn on serial key option.
- ⇒ Set the baud rate and COM port from the settings option.

- ⇒ Click OK to accept the settings for serial key.
- ⇒ Click APPLY and then OK to save the Accessibility options.

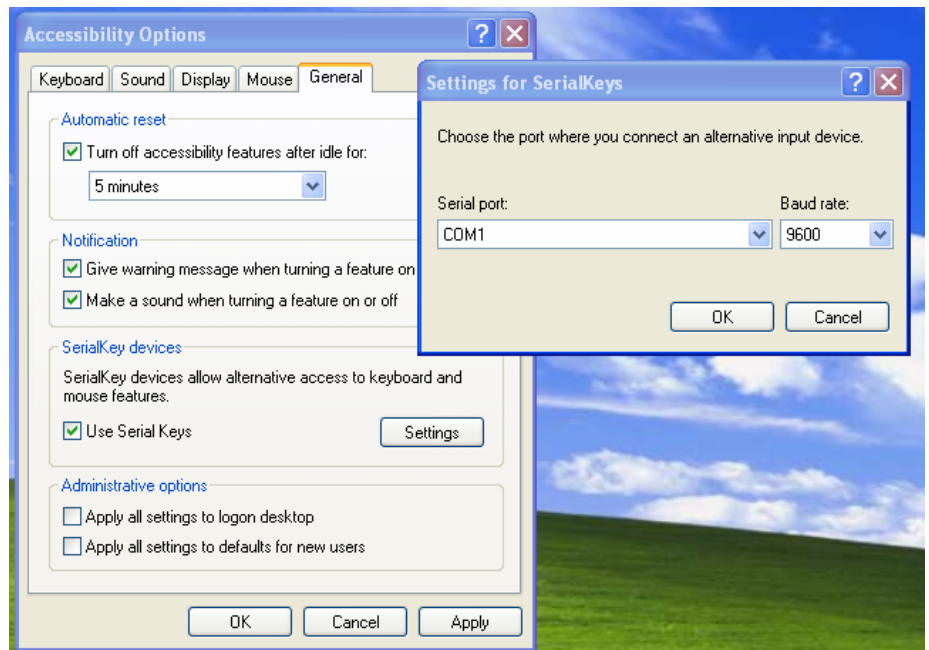

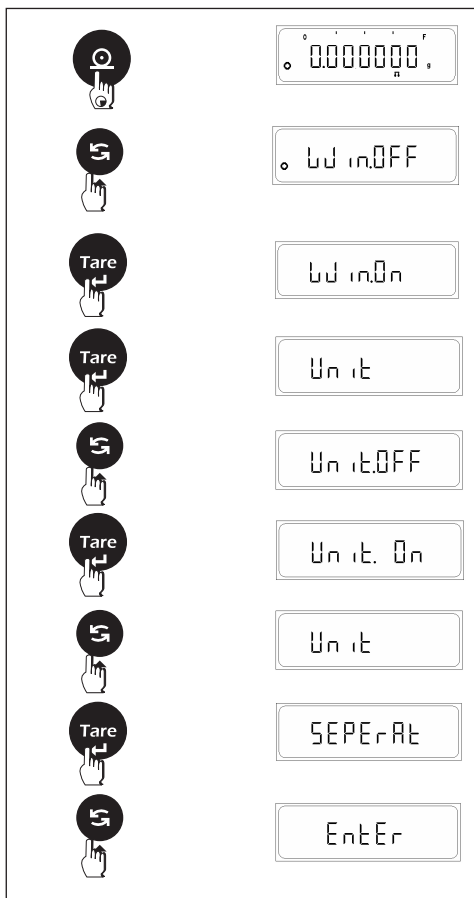

Windows direct communication settings (Balance Side)

- ⇒ Press and hold the <PRINT> key in simple weighing mode until the windows print menu is prompted.
- ⇒ Press the <TOGGLE> key briefly to change the windows option to ON of OFF. The default option is OFF.

Windows Unit settings

Select Windows print option as ON and press the <TARE> key, now press the <TARE> key when the LCM displays UNIT to enter unit settings.

User can set Unit option as ON (Along with the numerical value the unit will also be sent to windows).

User can set Unit option as OFF (Only the numerical value will be sent to windows and not the unit).

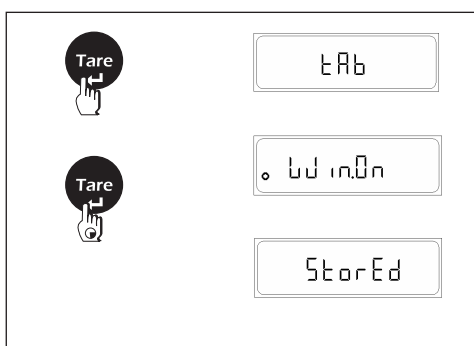

Windows Separator settings

Select Windows print option as ON and press the <TARE> key, now press the <TARE> key when the LCM displays 'Separat' to enter Separator settings.

User can set SEPERATOR option as ENTER (After every value printed on the windows side an ENTER command is given so every subsequent data will print on new line, in Excel every new data will be printed in new row).

User can set SEPERATOR option as TAB (After every value printed on the windows side a TAB command is given so every subsequent data will printed with tab, in Excel every new data will be printed in new column).

8. ISO/GLP-compliant Printout/Record

Features

You can have the parameters pertaining to the ambient weighing conditions printed before (GLP header) and after (GLP footer) the values of a weighing series. These parameters include:

GLP header:

- Date
- Time at beginning of measurement
- Balance manufacturer
- Balance model
- Balance serial number
- Software version number
- Identification number of the current sampling operation

GLP footer:

- Date
- Time at end of measurement
- Field for operator signature

The record is output to a ACZET data printer or a computer.

Settings

Set print option to request & GLP ON

Function Keys

Press the Print key to output header and first measured value.

End an Application:

Output GLP Footer : Press Cancel Key

End an application program Press Cancel key

45

9. Data Interface

Purpose

Your balance is equipped with an interface port for connection to a computer or other peripheral device.

You can use an on-line computer to change, start and/or monitor the functions of the balance and the application programs.

Features

- Type of interface: Serial interface
- Operating mode: Full duplex
- Standard: RS-232
- Transmission rates: 300; 600; 1,200; 2,400; 4,800; 9,600; 19,200 baud 57600
- Parity: Mark, space, odd, even, none
- Character format: 1 start bit, 8-bit ASCII, parity, 1 or 2 stop bits
- Handshake: None
- Data output format of the balance : 26 characters

Factory settings:

Transmission rate: 1,200 baud (9600)

Parity: Odd (none)

Stop bits: 1 stop bit

Handshake: None

Print manually/automatically: Manual at stability

Preparation

- See "Pin Assignments"

46

9.1 Output Format with 26 Characters

The following characters can be output, depending on the characters displayed on the balance :

Normal Operation

Position	1	2	3	4	5	6	7	8	9	10	11	12	13	14	15	16	17	18	19	20	21	22	23	24	25	26
	*	*	*	*	+	D	D	D	D	D	D	D	D	D	D	D	D	D	D	D	*	U	U	U	LF	CR
or	*	*	*	*	-	D	D	D	D	D	D	D	D	D	D	D	D	D	D	D	*	U	U	U	LF	CR
or	I	I	I	*	+	D	D	D	D	D	D	D	D	D	D	D	D	D	D	D	*	U	U	U	LF	CR

* : Space
 D : Digit or letter
 U : Unit Symbol
 CR : Carriage Return
 LF : Line Feed
 I : ID code Character

Special Codes

Position	1	2	3	4	5	6	7	8	9	10	11	12	13	14	15	16	17	18	19	20	21	22	23	24	25	26		
					-	-	-	-	-	-	-	O	L	-	-	-	-	-	-	-						LF	CR	
or					-	-	-	-	-	-	-	U	L	-	-	-	-	-	-	-							LF	CR
or					-	-	-	-	-	-	-	O	r	-	-	-	-	-	-	-							LF	CR
					-	-	-	-	-	-	-	L	L	-	-	-	-	-	-	-							LF	CR
					-	-	-	-	-	-	-	H	H	-	-	-	-	-	-	-							LF	CR

OL : Space
 Or : Digit or letter
 HH : Unit Symbol
 UL : Carriage Return
 LL : Line Feed

Data Output Examples + 123.4567 g

Position	1	2	3	4	5	6	7	8	9	10	11	12	13	14	15	16	17	18	19	20	21	22	23	24	25	26	
					+							1	2	3	.	4	5	6	7					g	LF	CR	
or					+							6	1	7	.	2	8	3	5					c	t	LF	CR
or	N	1			+							2	0	.	0	0	0	0						g	LF	CR	
or	T	o	t		+							6	0	.	0	0	0	0						g	LF	CR	

Position 1 - 4 : ID code Character or Space
 Position 5 : Sign
 Position 6 - 20 : Weight with Decimal Point; leading zeros = space
 Position 21 : Space
 Position 22 - 24 : Unit Symbol or Space
 Position 25 : Line Feed
 Position 26 : Carriage Return

ID code	characters	Meaning
	nRef	Counting: Reference sample quantity
	wRef	Piece Counting, Percentage Weighing : Reference weight
	Qnt	Piece Counting: Quantity
	pRef	Weighing in percent: Reference percentage
	Pct	Weighing in percent: Reference percentage
	Cnt	Animal weighing: No. of sub-weighing operations
	xNt	Animal weighing: Calculated average

ID Code	Characters	Meaning
	N1	Formulation, Totalization Net : N1
	N	Formulation, Totalization Net N
	Tot	Formulation, Totalization : Total Weight
	Pur	density : Purity of Gold
	Den	Density : density of sample
	Pip	Pipette Calibration
	Sta	Statistics : to obtain the statistics of the data

9.2 Data Input Format

You can connect a computer to your balance to send commands via the balance interface port to control balance functions and applications.

Format for commands

[Command Code	Data]
---	--------------	------	---

- [: it shows start of command frame.
- Command Code: it shows which functionality to be carried out for this command frame.
- Data: This field in frame is optional and it is intended to provide data information between Bi-directional communications.
-]: it shows end of command frame.

Commands

[W] : If host computer send this command to balance then balance will Send weight with current unit.

[T] : If host computer send this command then balance will do taring in balance. If stability is not achieved within 45 second then it comes to that specific feature fill that time it shows "-----"on LCM.

9.3 Cabling Diagram

- For connecting a computer or other peripheral device to the balance using the RS-232 protocol and cables up to 15m (50 ft.) long.

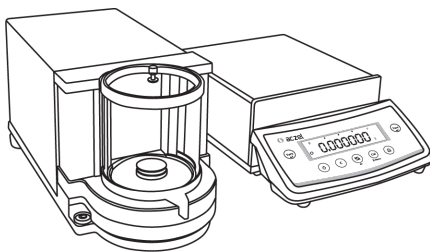

RS-232

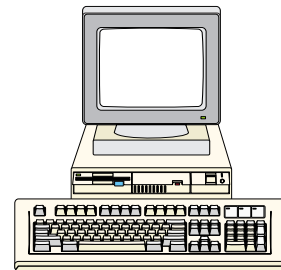

Balance
DB 9 Female Connector

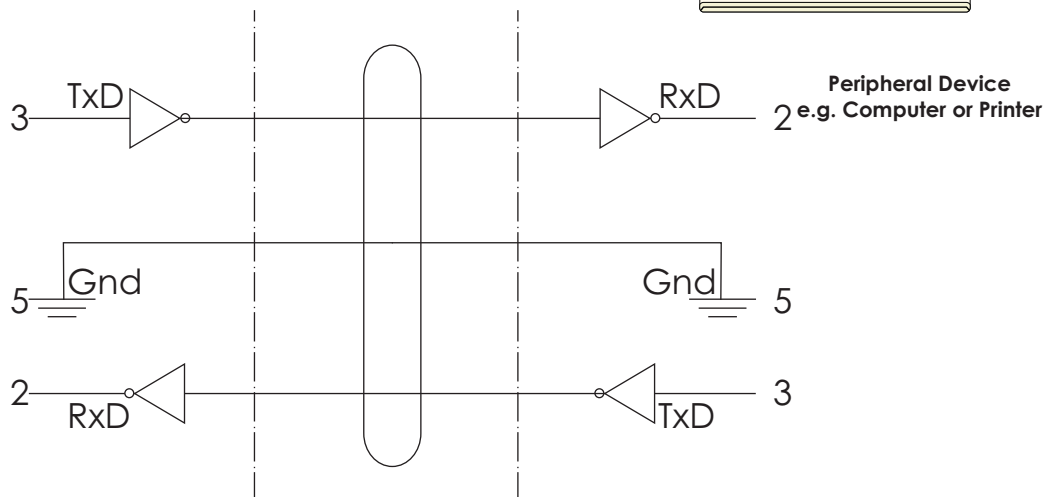

10. Error Codes

Display	Cause	Solution
--OL--	Overload	Remove excess weight from the weighing pan.
--UL--	Under load	<ul style="list-style-type: none"> Keep weighing Pan on Weighing Shaft. Check whether weighing pan is positioned properly.
Error 1	Weight set is too low for storing any reference at PCS, %, Custom Unit or Check Weighing.	Increase weight on the pan.
Error 2	While calibrating the scale, the load on the pan is more than 10% of the capacity. (During power on of the scale.)	Switch OFF the Balance and Switch ON again without any load on the pan.
Error 3	Calibration <ul style="list-style-type: none"> User does not keep any weight on the pan within 60 second. Weight load on the pan is not within the tolerance limit. 	<ul style="list-style-type: none"> Add the calibration weight on the pan when demanded by the balance Calibrate with the exact Calibration Weight.
Error 4	GLP is ON and user tries to enter in to the User Menu before the footer is printed.	Print the footer first, by pressing <CANCEL> key, and then access the USER MENU.
Error 6	Calibration Display shows any weight other than 0.00 and user tries to Calibrate the balance	Tare the balance or enter Calibration procedure when "0.00 g" is displayed.
Error 7	Incorrect value of TIME or DATE.	Enter proper value of TIME or DATE.

Display	Cause	Solution
Error 8	Last stored PRINT option is AUTO or AUTO LOAD or CONTINUOUS and user tries to set GLP ON from USER MENU.	Change the print option to Print on REQUEST and then turn GLP ON.
Error 9	RTC not operational.	Contact Aczet Service center.
Error29	Error 2 Calibration Error + RTC Error.	Contact Aczet Service center.
Error39	Error 3 Calibration Error + RTC Error.	Contact Aczet Service center.
The weight readout changes constantly	Unstable ambient conditions A foreign object is caught between the load plate and the balance/scale frame	Set up the balance/scale in another area Remove the foreign object
The weight readout is obviously wrong	The balance has not been calibrated / adjusted. The balance was not zeroed before weighing.	Calibrate / Adjust the balance. Tare or Zero the balance before weighing.

11. Care & Maintenance

Service

Regular servicing by a ACZET technician will extend the service life of your balance and ensure its continued weighing accuracy. ACZET can offer you service contracts, with your choice of regular maintenance intervals.

The optimum maintenance interval depends on the operating conditions at the place of installation and on the individual tolerance requirements.

Repairs

Repair work must be performed by trained service technicians. Any attempt by untrained persons to perform repairs may lead to hazards for the user.

Cleaning

- Unplug the DC adapter from the wall outlet (mains supply). If you have an interface cable connected to the balance/scale port, unplug it from the port.
- Make sure that no liquid enters the balance/scale housing
- Do not use any aggressive cleaning agents (solvents or similar agents)
- Clean the balance/scale using a piece of cloth which has been wet with a mild detergent (soap)
- After cleaning, wipe down the balance/scale with a soft, dry cloth

Cleaning Stainless Steel Surfaces

- Clean all stainless steel parts regularly. Remove the stainless steel weighing pan and thoroughly clean it separately. Use a damp cloth or sponge to clean any stainless steel parts on the scale. You can use any commercially available household cleaning agent that is suitable for use on stainless steel. Clean stainless steel surfaces by wiping them down. Then clean the weighing pan thoroughly, making sure to remove all residues. Use a damp cloth or sponge to wipe down any stainless steel parts on the scale again. Afterwards, allow the scale to dry. If desired, you can apply oil to the cleaned surfaces as additional protection.
- Do not use stainless steel cleaning agents that contain soda lye (caustic), acetic acid, hydrochloric acid, sulfuric acid or citric acid. The use of scrubbing sponges made of steel wool is not permitted. Solvents are permitted for use only on stainless steel parts.

Safety Inspection

If there is any indication that safe operation of the balance/scale with the DC adapter is no longer warranted:

- Turn off the power and disconnect the equipment from DC power immediately
- Lock the equipment in a secure place to ensure that it cannot be used for the time being.
- Safe operation of the balance/scale with the DC adapter is no longer ensured when:
 - There is visible damage to the DC adapter.
 - The DC adapter no longer functions properly.
 - The DC adapter has been stored for a relatively long period under unfavorable conditions.

LIMITED WARRANTY

ACZET products are warranted against defects in materials and workmanship from the date of delivery through the duration of the warranty period. During the warranty period Aczet will repair, or, at its option, replace any component (s) that proves to be defective at no charge, provided that the product is returned, freight prepaid, to ACZET.

This warranty does not apply if the product has been damaged by accident or misuse, exposed to radioactive or corrosive materials, has foreign material penetrating to the inside of the product, or as a result of service or modification by other than ACZET. In lieu of a properly returned warranty registration card, the warranty period shall begin on the date of shipment to the authorized dealer. No other express or implied warranty is given by Aczet Pvt. Ltd.

As warranty legislation differs from state to state and country to country, please contact aczet or your local ACZET dealer for further details.

ACZET service center will repair the product free of charge subject to terms & condition mentioned below.

TERMS & CONDITION

1. It covers only weighing balance purchased from authorized channel and does not cover accessories like Battery, Adaptor, RS232 cable, Pan, Pan support etc
2. It does not cover the product of which model and serial number has been altered, removed or defaced and / or is open by unauthorized person and found void sticker has been tampered.
3. This warranty is non-transferable and applicable only to first end user purchasing the product from authorized dealer.
4. For repair based on this warranty you need to hand over this product or send this product to address mentioned in warranty card in original packing, enclosing copy of this warranty card.'
5. Aczet Pvt. Ltd. shall not be liable for any consequential damages.

WARRANTY REGISTRATION



ACZET SCALES (I) PVT.LTD.

Unit E2, Plot No. 15, WICEL Estate, Opp. Seepz Gate no. 1,
Andheri (E), Mumbai - 400 093. Maharashtra, India
e-mail :- service@aczetcales.com • web.: www.aczetcales.com
Tel. No. :- +91-22-4243 7700 • Fax :- +91-22-4243 7800

NAME :-

ADDRESS :-

TEL NO. :-

MODEL NO. :-

SERIAL NO. :-

PURCHASE DATE :-

BRANCH / DISTRIBUTOR / DEALER CONTACT DETAILS

WARRANTY PERIOD :-

STAMP / SIGN

Owners Signature / Date

SEND YOUR WARRANTY CARD DULY FILL TO ABOVE ADDRESS FOR REGISTRATION

13. Specification Micro Balance

Model		CM 2	CM 5	CM 2F	CM 5F
Weighing Capacity	gm	2	1	2	5
Readability (d)	µg	1	1	1	1
Accuracy (e)	mg	1	1	1	1
Tare Range (Subtractive)	gm	-2	-5	-2	-5
Repeatability (std. deviation)	<=µg	1	1	1	1
Linearity	<=µg	3	5	3	3
Weighing Class		II	II	I	I
Response time (average)	s	8-10 sec.			
Operating temperature range	°C	18° to 30°C	18° to 30°C	18° to 30°C	18° to 30°C
Calibration		Internal	Internal	Internal	Internal
External calibration weight (of at least accuracy class...)		2	5	2	5
Net Weight, approx.	kg	10.20 / 14.70			
Pan size	mm	15 ~ 30 Ø			
Weighing chamber height	mm	Ø75 x 86.5			
Dimensions for Electronic Box (W x D x H)	mm	240 x 210 x 65			
Dimensions for Mechanical Box (L x W x H)	mm	360 x 140 x 146			
Packing Dimension (L x W x H)	mm	565 x 565 x 355			
DC power source / Power requirements	V~	AC Adaptor 230V or 115V +/- 20%			⊕ ⊖
Frequency	Hz	50 / 60Hz			
Power consumption (average)	VA	maximum 18; typical 9			
Selectable weight units		gram, ounce, troy ounce, grain, pennyweight, carat, Milligram, momme, mesghal, Hong Kong taels, Singapore taels, Taiwan taels, baht			
Built-in-interface		RS-232 / USB			
Format		1 start bit, 8-bit ASCII, parity, 1 or 2 stop bits			
Parity		Mark, Space, Odd, even, none			
Transmission rates :		300; 600; 1200; 2400; 4800; 9600; 19200; 57600 baud			
Handshake mode		None			

57

14. Accessories (Option)

Statistical Printer "CPR 02"

with Date / Time & Statistics

Remote Display "SRD01"

Calibration Weights

(F1) (ERTL, F2 with certificate) for further details, contact ACZET Dealers.

USB Interface

Density Kit "CDK 01"

For determination of solids for determination of liquids with displacement body

Antitheft device

Cable and lock (for all models)

Dust Cover

Subject to technical changes and to the availability of the accessories supplied with the instruments.

ACZET Inc.
1637, STELTON ROAD UNIT B-5, PISCATAWAY, NJ-08854. USA | Email: service@aczet.com | Web: www.aczet.com

CS-09-05-11/2